

CONCRETE POLE 
 6' OR 8' REACH OR 7' RISE
 COBRA HEAD LUMINAIRE BRACKET

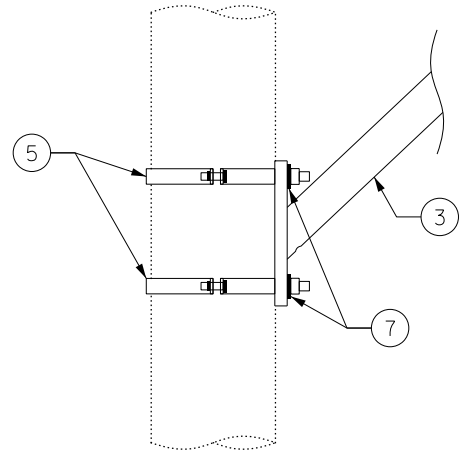

STEEL POLE 
 7' RISE COBRA HEAD LUMINAIRE BRACKET

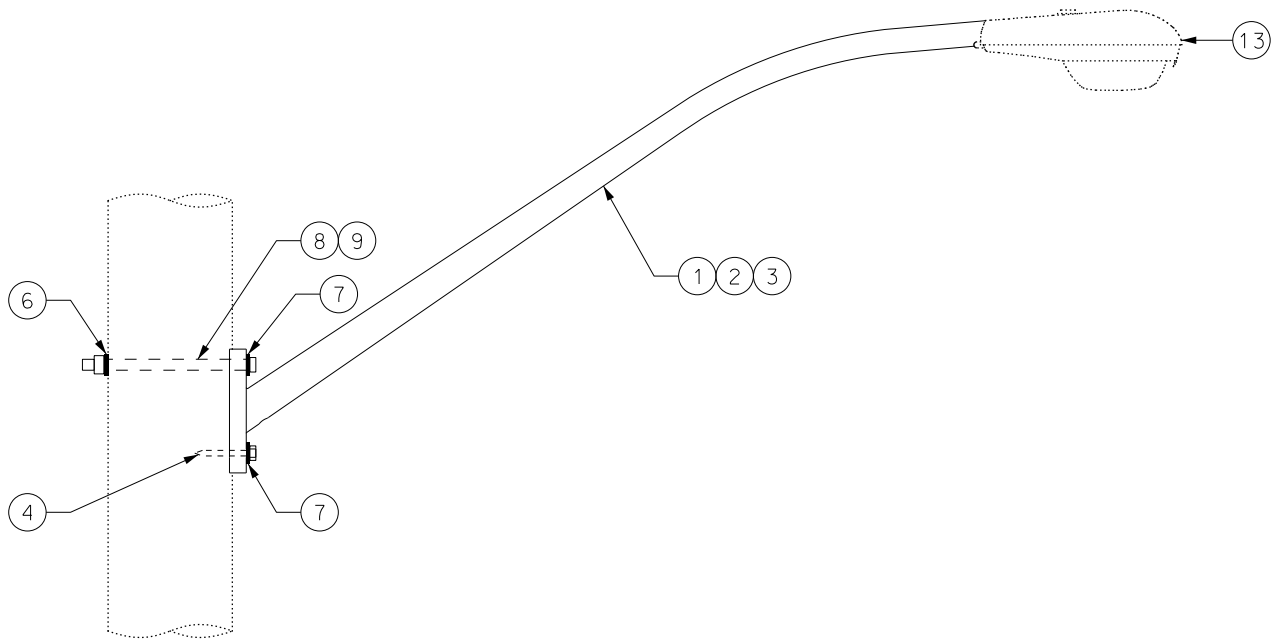

WOOD POLE 
 6' OR 8' REACH OR 7' RISE COBRA HEAD LUMINAIRE BRACKET

NOTES: 

1) REFER TO STANDARD 30-1600 FOR STREET LIGHT BRACKET DETAILS.

DISTRIBUTION CONSTRUCTION STANDARD
 Street Lighting

COBRA HEAD LUMINAIRE WITH BRACKET 
 TYPICAL INSTALLATION ON CONCRETE, WOOD, OR STEEL POLE



Approved By:
 J.D. 2016-07-28

Drafted By: D.C.
 Designed By: J.D.

Original Issue:
 L.G. 2001-06-15

Scale:
 N.T.S.

Rev: **3**

30-4240

1/2



BOM LEGEND				
	POLE TYPE	POLE HEIGHT	BOLT LENGTH	BRACKET
A	CONCRETE	25', 30', 34', 38'-6", 40'	305 mm (12")	6' REACH
B				8' REACH
C				7' RISE
D		45', 50', 55', 60'	406 mm (16")	6' REACH
E				8' REACH
F				7' RISE
G	WOOD	30', 35', 40'	305 mm (12")	6' REACH
H				8' REACH
I				7' RISE
J		45', 50', 55', 60'	406 mm (16")	6' REACH
K				8' REACH
L				7' RISE
M	STEEL	30'	-	7' RISE



BILL OF MATERIALS FOR 30-4240

ITEM NO.	DESCRIPTION	ITEM I.D.	QUANTITY														
			A	B	C	D	E	F	G	H	I	J	K	L	M		
1	BRACKET AL TAPERED 6' REACH	7900012	1	-	-	1	-	-	1	-	-	1	-	-	1	-	-
2	BRACKET AL TAPERED 8' REACH	7900014	-	1	-	-	1	-	-	1	-	-	1	-	-	1	-
3	BRACKET AL TAPERED 7' RISE	7900015	-	-	1	-	-	1	-	-	1	-	-	1	-	-	1
4	LAG SCREW 5/8" X 5" GALV GIMLET POINT	2550030	-	-	-	-	-	-	-	1	1	1	1	1	1	1	-
5	POLE BAND 219 mm	2450034	-	-	-	-	-	-	-	-	-	-	-	-	-	-	1
OPEN BIN MATERIALS																	
6	WASHER CURVED SQUARE GALV 2" X 2" FOR 5/8" BOLT	2530020	1	1	1	1	1	1	1	1	1	1	1	1	1	1	1
7	WASHER SQUARE GALV 2" X 2" FOR 5/8" BOLT	2530003	1	1	1	1	1	1	1	2	2	2	2	2	2	2	2
8	BOLT MACHINE 5/8" X 12" C/W SQUARE HEAD AND NUT	2510190	1	1	1	-	-	-	1	1	1	-	-	-	-	-	-
9	BOLT MACHINE 5/8" X 16" C/W SQUARE HEAD AND NUT	2510203	-	-	-	1	1	1	-	-	-	-	1	1	1	1	-
10	BANDING STAINLESS STEEL 3/4" X 0.030" X 100' ROLL	8220072	+	+	+	+	+	+	+	-	-	-	-	-	-	-	-
11	BUCKLE BANDING 3/4" STAINLESS STEEL	7903986	+	+	+	+	+	+	+	-	-	-	-	-	-	-	-
ASSOCIATED STANDARDS																	
12	O/H SUPPLY TO POLE-MOUNTED LUMINAIRE	STD. 30-3600	1	1	1	1	1	1	1	1	1	1	1	1	1	1	1
13	COBRA HEAD LUMINAIRE SELECTION TABLE	STD. 30-1110	1	1	1	1	1	1	1	1	1	1	1	1	1	1	1

+ AS REQUIRED.

DISTRIBUTION CONSTRUCTION STANDARD
Street Lighting



Approved By:
J.D. 2016-07-28

Drafted By: J.D.
Designed By: J.D.

COBRA HEAD LUMINAIRE WITH BRACKET
TYPICAL INSTALLATION ON CONCRETE, WOOD, OR STEEL POLE

Original Issue:
L.G. 2001-06-15

Scale:
N.T.S.

Rev:

3

30-4240

2/2